

CCL METER

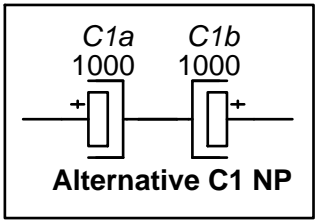
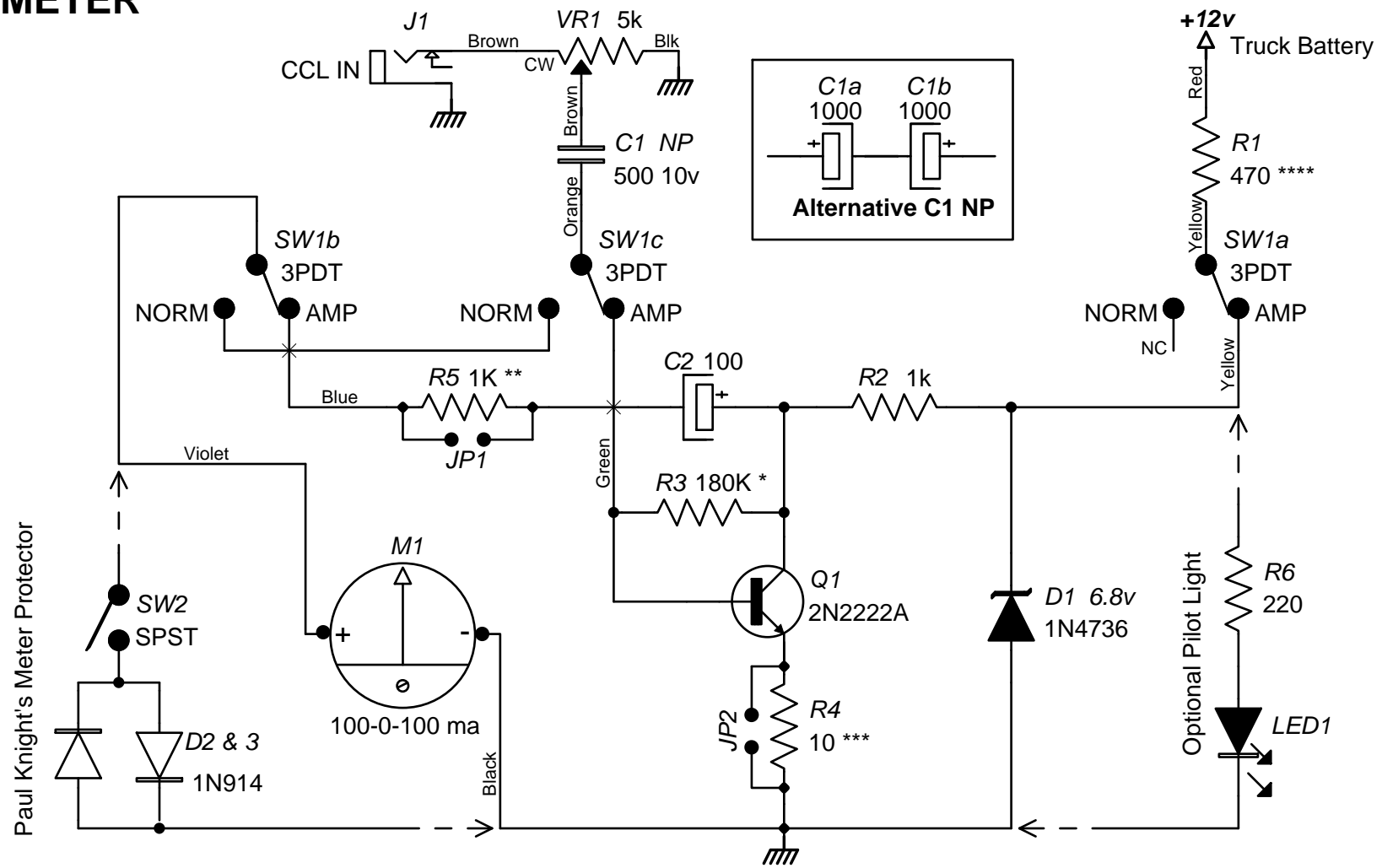

Copyright 2000 by AnaLog Services, Inc. All rights reserved. Reproduction is unlawful without express written permission.

NOTES:

- * Select R3 for approximately 3 volts at collector (not critical).
- ** Omit R5 if M1 is to be a 500-0-500 microamp meter (shunt JP1).
- *** Omit emitter resistor R4 for maximum gain (shunt JP2).
- **** R1 is 200 ohms when using the optional LED pilot.

Use of or reliance on this schematic is entirely at your own risk.

AnaLog Services, Inc.

1169 Haynesville Road - Reynolds Station, KY 42368 (270) 276-5671 Fax: (270) 276-5588

CCL Meter		CCLM2a.sch
Sheet Size: A	Creation Date: 10/21/2000	Drawn By: Syd H. Levine
Revision: 1.0	Modify Date: 11/11/2009	Sheet 1 of 1